

- NOTES:
1. MATERIAL OF CONSTRUCTION IS MILD STEEL.
 2. 2-4 MILS SD FINE BLACK TEX POWDER COAT.
1. PWDR-BLACK-TEX

PEDESTALPRO.COM
1-800-660-3072

UNLESS OTHERWISE SPECIFIED:
DIMENSIONS ARE IN INCHES
TOLERANCES:
FRACTIONAL $\pm 1/32$
ANGULAR: $\pm 2^\circ$
TWO PLACE DECIMAL ± 0.010
THREE PLACE DECIMAL ± 0.005
INTERPRET GEOMETRIC
TOLERANCING PER:
ASME Y14.5 -2009

NAME	DATE
DRAWN	
CHECKED	
PROPRIETARY AND CONFIDENTIAL	
THE INFORMATION CONTAINED IN THIS DRAWING IS THE SOLE PROPERTY OF PEDESTALPRO LLC. ANY REPRODUCTION IN PART OR AS A WHOLE WITHOUT THE WRITTEN PERMISSION OF PEDESTALPRO LLC IS PROHIBITED.	

TITLE:
INSTALLATION
Tuesday, April 21, 2026
7:19:03 AM
WEIGHT: 9.211

SIZE A	PART NO. XBUT-HD001C	REV 0
NO SCALE		SHEET 1 OF 9

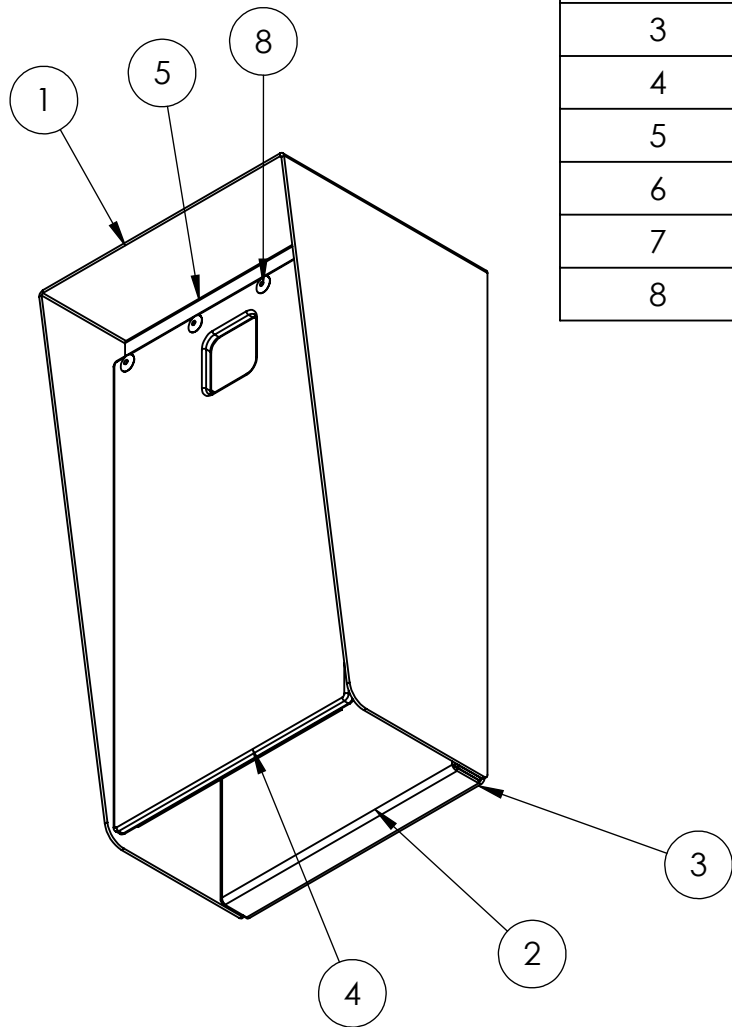

ITEM NO.	PART NUMBER	DESCRIPTION	QTY.
1	XBUT-HD001C HOOD	HOOD ASSEMBLY	1
2	XBUT-HD001C MID PLATE	MOUNTING PLATE	1
3	XBUT-HD001C BACK PLATE	BACK PLATE	1
4	XBUT-HD001C SHIELD	UV RESISTANT WHITE AVRYLIC	1
5	XBUT-HD001C BRACKET	BRACKET	1
6	XBUT-HD001C GASKET	GASKET	1
7	HINGE	PIANO HINGE	1
8	--	3/16 X .55" BLIND RIVET	4

NOTES:

- SEE STANDARD PREPARATION AND COATING INSTRUCTIONS FOR COATING PROCEDURE AND COLOR.
- SEE STANDARD PACKAGING INSTRUCTIONS FOR PACKAGING PROCEDURE.

PEDESTALPRO.COM
1-800-660-3072

UNLESS OTHERWISE SPECIFIED:

DIMENSIONS ARE IN INCHES
TOLERANCES:
FRACTIONAL $\pm 1/32$
ANGULAR: $\pm 2^\circ$
TWO PLACE DECIMAL ± 0.010
THREE PLACE DECIMAL ± 0.005

INTERPRET GEOMETRIC
TOLERANCING PER:
ASME Y14.5 -2009

NAME	DATE
DRAWN	
CHECKED	

PROPRIETARY AND CONFIDENTIAL
THE INFORMATION CONTAINED IN THIS
DRAWING IS THE SOLE PROPERTY OF
PEDESTALPRO LLC. ANY REPRODUCTION
IN PART OR AS A WHOLE WITHOUT THE
WRITTEN PERMISSION OF PEDESTALPRO LLC
IS PROHIBITED.

TITLE:

ASSEMBLY

Tuesday, April 21, 2026
7:19:03 AM

WEIGHT: 9.211

SIZE
A

PART NO.
XBUT-HD001C

REV
0

NO SCALE

SHEET 2 OF 9