

- NOTES:
1. MATERIAL OF CONSTRUCTION IS MILD STEEL.
 2. 2-4 MILS SD FLAT BLACK POWDER COAT.
 1. PWDR-BLACK-FLAT



PEDESTALPRO.COM
1-800-660-3072

UNLESS OTHERWISE SPECIFIED:

DIMENSIONS ARE IN INCHES
TOLERANCES:
FRACTIONAL $\pm 1/32$
ANGULAR: $\pm 2^\circ$
TWO PLACE DECIMAL ± 0.010
THREE PLACE DECIMAL ± 0.005

INTERPRET GEOMETRIC
TOLERANCING PER:
ASME Y14.5 -2009

NAME DATE

DRAWN

CHECKED

PROPRIETARY AND CONFIDENTIAL

THE INFORMATION CONTAINED IN THIS
DRAWING IS THE SOLE PROPERTY OF
PEDESTALPRO LLC. ANY REPRODUCTION
IN PART OR AS A WHOLE WITHOUT THE
WRITTEN PERMISSION OF PEDESTALPRO LLC
IS PROHIBITED.

TITLE:

INSTALLATION

Wednesday, January
14, 2026 12:49:05 PM

WEIGHT: 2.615

SIZE
A

PART NO.

J-HOOD-CS-4.5X8

NO SCALE

REV
A

SHEET 1 OF 8

ITEM NO.	PART NUMBER	DESCRIPTION	QTY.
1	J-HOOD-CS-4.5X8 HOOD	HOOD	1
2	J-HOOD-CS-4.5X8 MID PLATE	DEVICE MOUNTING PLATE	1
3	J-HOOD-CS-4.5X8 BOTTOM CLOSURE	BOTTOM CLOSURE	1
4	J-HOOD-CS-4.5X8 BACK PLATE	WALL MOUNTING PLATE	1
5	J-HOOD-CS-4.5X8 HOOK	MOUNTING HOOK	1
6	--	6-32 X 1.25" SS TAMPER-RESISTANT TORX SECURITY SCREW	2
7	--	6-32 X 3/8 SS PEM STUD	2
8	--	6-32 KEPS NUT	2

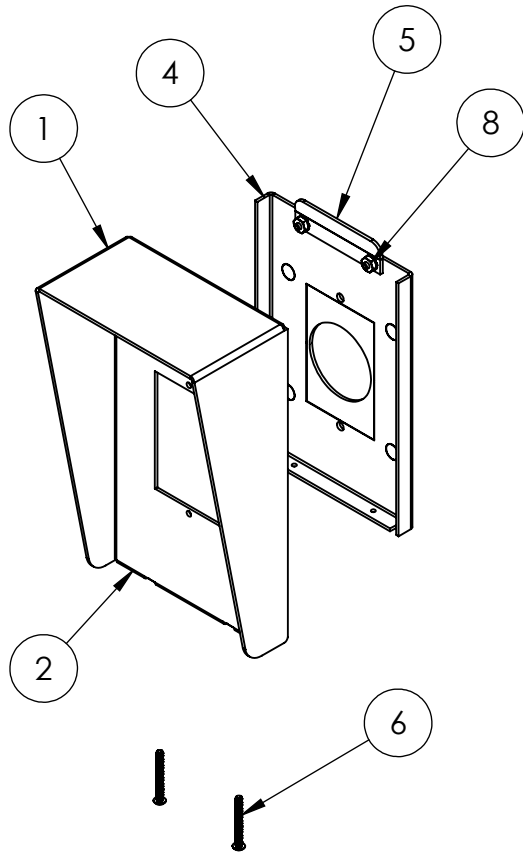

NOTES:

- SEE STANDARD PREPARATION AND COATING INSTRUCTIONS FOR COATING PROCEDURE AND COLOR.
- SEE STANDARD PACKAGING INSTRUCTIONS FOR PACKAGING PROCEDURE.



PEDESTALPRO.COM
1-800-660-3072

UNLESS OTHERWISE SPECIFIED:

DIMENSIONS ARE IN INCHES
TOLERANCES:
FRACTIONAL $\pm 1/32$
ANGULAR: $\pm 2^\circ$
TWO PLACE DECIMAL ± 0.010
THREE PLACE DECIMAL ± 0.005

INTERPRET GEOMETRIC
TOLERANCING PER:
ASME Y14.5 -2009

NAME	DATE
DRAWN	
CHECKED	

PROPRIETARY AND CONFIDENTIAL
THE INFORMATION CONTAINED IN THIS DRAWING IS THE SOLE PROPERTY OF PEDESTALPRO LLC. ANY REPRODUCTION IN PART OR AS A WHOLE WITHOUT THE WRITTEN PERMISSION OF PEDESTALPRO LLC IS PROHIBITED.

TITLE:

ASSEMBLY

Wednesday, January
14, 2026 12:49:05 PM

WEIGHT: 2.615

SIZE
A

PART NO.
J-HOOD-CS-4.5X8

REV
A

NO SCALE

SHEET 2 OF 8