

DETAIL A

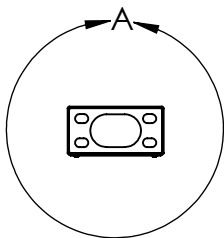

- NOTES:
 1. MATERIAL OF CONSTRUCTION IS 304 SS, BRUSHED #4.

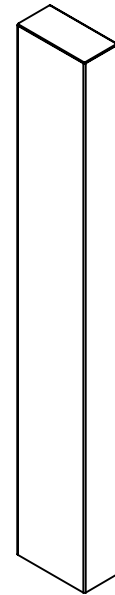

PEDESTALPRO.COM
 1-800-660-3072

UNLESS OTHERWISE SPECIFIED:

DIMENSIONS ARE IN INCHES
 TOLERANCES:
 FRACTIONAL $\pm 1/32$
 ANGULAR: $\pm 2^\circ$
 TWO PLACE DECIMAL ± 0.010
 THREE PLACE DECIMAL ± 0.005

INTERPRET GEOMETRIC
 TOLERANCING PER:
 ASME Y14.5 -2009

NAME	DATE
DRAWN	
CHECKED	

PROPRIETARY AND CONFIDENTIAL
 THE INFORMATION CONTAINED IN THIS
 DRAWING IS THE SOLE PROPERTY OF
 PEDESTALPRO LLC. ANY REPRODUCTION
 IN PART OR AS A WHOLE WITHOUT THE
 WRITTEN PERMISSION OF PEDESTALPRO LLC
 IS PROHIBITED.

TITLE:
INSTALLATION

Friday, June 16, 2023
 7:13:30 AM

WEIGHT: 45.659

SIZE	PART NO.	REV
A	84TOW-PRO-01-304	A
NO SCALE		SHEET 1 OF 8

ITEM NO.	PART NUMBER	DESCRIPTION	QTY.
1	MAIN BODY	MAIN BODY	1
2	TOP	TOP	1
3	BOTTOM CLOSURE	BOTTOM CLOSURE	1
4	BASE PLATE	BASE PLATE	1
5	ACCESS PANEL	ACCESS PANEL	1
6	--	8-32 X 1/2" PAN HEAD SCREW	10
7	STIFFENER	STIFFENER	1

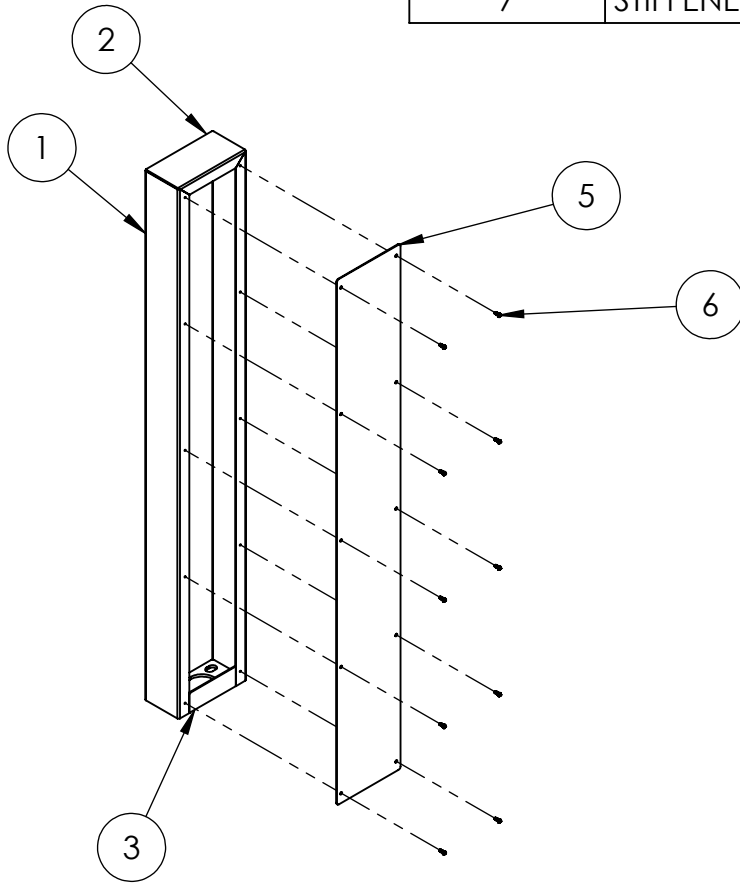

NOTES:

1. SEE STANDARD PREPARATION AND COATING INSTRUCTIONS FOR COATING PROCEDURE AND COLOR.
2. SEE STANDARD PACKAGING INSTRUCTIONS FOR PACKAGING PROCEDURE.



PEDESTALPRO.COM
1-800-660-3072

UNLESS OTHERWISE SPECIFIED:

DIMENSIONS ARE IN INCHES
TOLERANCES:
FRACTIONAL $\pm 1/32$
ANGULAR: $\pm 2^\circ$
TWO PLACE DECIMAL ± 0.010
THREE PLACE DECIMAL ± 0.005

INTERPRET GEOMETRIC
TOLERANCING PER:
ASME Y14.5 -2009

NAME DATE

DRAWN

CHECKED

PROPRIETARY AND CONFIDENTIAL

THE INFORMATION CONTAINED IN THIS
DRAWING IS THE SOLE PROPERTY OF
PEDESTALPRO LLC. ANY REPRODUCTION
IN PART OR AS A WHOLE WITHOUT THE
WRITTEN PERMISSION OF PEDESTALPRO LLC
IS PROHIBITED.

TITLE:

ASSEMBLY

Friday, June 16, 2023
7:13:30 AM

WEIGHT: 45.659

SIZE
A

PART NO.

84TOW-PRO-01-304

NO SCALE

REV
A

SHEET 2 OF 8