

- NOTES:
 1. MATERIAL OF CONSTRUCTION IS 304 SS, BRUSHED #4.



PEDESTALPRO.COM
 1-800-660-3072

UNLESS OTHERWISE SPECIFIED: ★

DIMENSIONS ARE IN INCHES
 TOLERANCES:
 FRACTIONAL: $\pm 1/32$
 ANGULAR: $\pm 2^\circ$
 TWO PLACE DECIMAL: ± 0.010
 THREE PLACE DECIMAL: ± 0.005

INTERPRET GEOMETRIC
 TOLERANCING PER:
 ASME Y14.5 -2009

★	NAME	DATE
DRAWN	PE	
CHECKED		

PROPRIETARY AND CONFIDENTIAL
 THE INFORMATION CONTAINED IN THIS
 DRAWING IS THE SOLE PROPERTY OF
 PEDESTALPRO LLC. ANY REPRODUCTION
 IN PART OR AS A WHOLE WITHOUT THE
 WRITTEN PERMISSION OF PEDESTALPRO LLC
 IS PROHIBITED.

TITLE:
INSTALLATION

Wednesday, August 13,
 2025 2:47:10 PM

WEIGHT: 7.233

SIZE	PART NO.	REV
A	68HOU-SALT-01-304	C
NO SCALE		SHEET 1 OF 6

ITEM NO.	PART NUMBER	DESCRIPTION	QTY.
1	68HOU-SALT-01-304 ENCLOSURE	ENCLOSURE WELDMENT	1
2	68HOU-SALT-01-304 DOOR	DOOR WELDMENT	1
3	68HOU-SALT-01-304 HOOD	HOOD	1
4	HINGE	PIANO HINGE	1
5	CAM LOCK	STRAIGHT CAM	1
6	GASKET SIDE	3/8" X .150 WEATHERSTRIPPING	2
7	GASKET TOP	3/8" X .150 WEATHERSTRIPPING	1
8	--	6-32 PAN HEAD SCREW	2
9	--	6-32 EXTERNAL TOOTH LOCK NUT	2

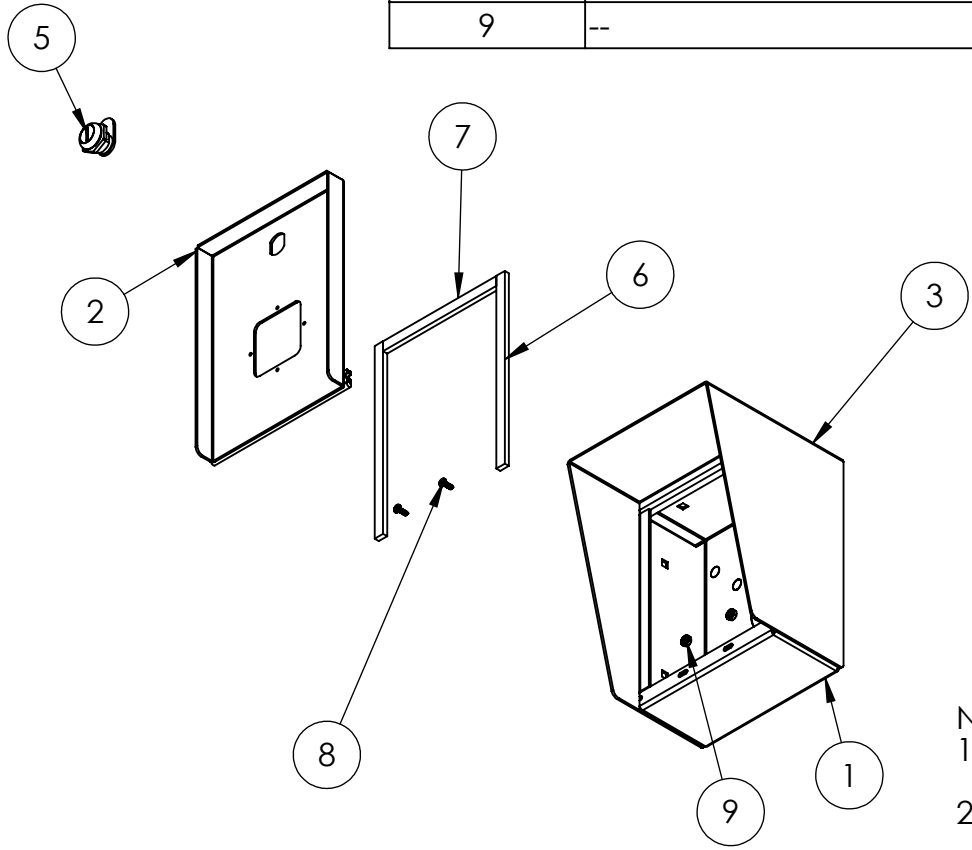

- NOTES:
- SEE STANDARD PREPARATION AND COATING INSTRUCTIONS FOR COATING PROCEDURE AND COLOR.
 - SEE STANDARD PACKAGING INSTRUCTIONS FOR PACKAGING PROCEDURE.



PEDESTALPRO.COM
1-800-660-3072

UNLESS OTHERWISE SPECIFIED:

DIMENSIONS ARE IN INCHES
TOLERANCES:
FRACTIONAL $\pm 1/32$
ANGULAR: $\pm 2^\circ$
TWO PLACE DECIMAL ± 0.010
THREE PLACE DECIMAL ± 0.005

INTERPRET GEOMETRIC TOLERANCING PER: ASME Y14.5 -2009

NAME	DATE
DRAWN	
CHECKED	

PROPRIETARY AND CONFIDENTIAL

THE INFORMATION CONTAINED IN THIS DRAWING IS THE SOLE PROPERTY OF PEDESTALPRO LLC. ANY REPRODUCTION IN PART OR AS A WHOLE WITHOUT THE WRITTEN PERMISSION OF PEDESTALPRO LLC IS PROHIBITED.

TITLE:
ASSEMBLY

Wednesday, August 13,
2025 2:47:10 PM

WEIGHT: 7.233

SIZE A	PART NO. 68HOU-SALT-01-304	REV C
NO SCALE		SHEET 2 OF 6