

- NOTES:
1. MATERIAL OF CONSTRUCTION IS MILD STEEL.
  2. 2-4 MILS BLACK WRINKLE POWDER COAT.
    1. PWDR-BLACK-WRINKLE



PEDESTALPRO.COM  
1-800-660-3072

UNLESS OTHERWISE SPECIFIED:

DIMENSIONS ARE IN INCHES  
TOLERANCES:  
FRACTIONAL  $\pm 1/32$   
ANGULAR:  $\pm 2^\circ$   
TWO PLACE DECIMAL  $\pm 0.010$   
THREE PLACE DECIMAL  $\pm 0.005$

INTERPRET GEOMETRIC  
TOLERANCING PER:  
ASME Y14.5 -2009

NAME	DATE
DRAWN PE	
CHECKED	

**PROPRIETARY AND CONFIDENTIAL**  
THE INFORMATION CONTAINED IN THIS DRAWING IS THE SOLE PROPERTY OF PEDESTALPRO LLC. ANY REPRODUCTION IN PART OR AS A WHOLE WITHOUT THE WRITTEN PERMISSION OF PEDESTALPRO LLC IS PROHIBITED.

TITLE:  
**INSTALLATION**

Tuesday, November 25, 2025 3:51:40 PM

WEIGHT: 2.958

SIZE	PART NO.	REV
<b>A</b>	48HOO-CREW-01-CRS	<b>A</b>

NO SCALE

SHEET 1 OF 8

ITEM NO.	PART NUMBER	DESCRIPTION	QTY.
1	48HOO-CREW-01-CRS HOOD	HOOD	1
2	48HOO-CREW-01-CRS MID PLATE	DEVICE MOUNTING PLATE	1
3	48HOO-CREW-01-CRS BOTTOM CLOSURE	BOTTOM CLOSURE	1
4	48HOO-CREW-01-CRS BACK PLATE	WALL MOUNTING PLATE	1
5	48HOO-CREW-01-CRS HOOK	MOUNTING HOOK	1
6	--	6-32 X 1/2" PAN HEAD SECURITY SCREW	2
7	--	6-32 X 3/8 SS PEM STUD	2
8	--	6-32 KEPS NUT	2

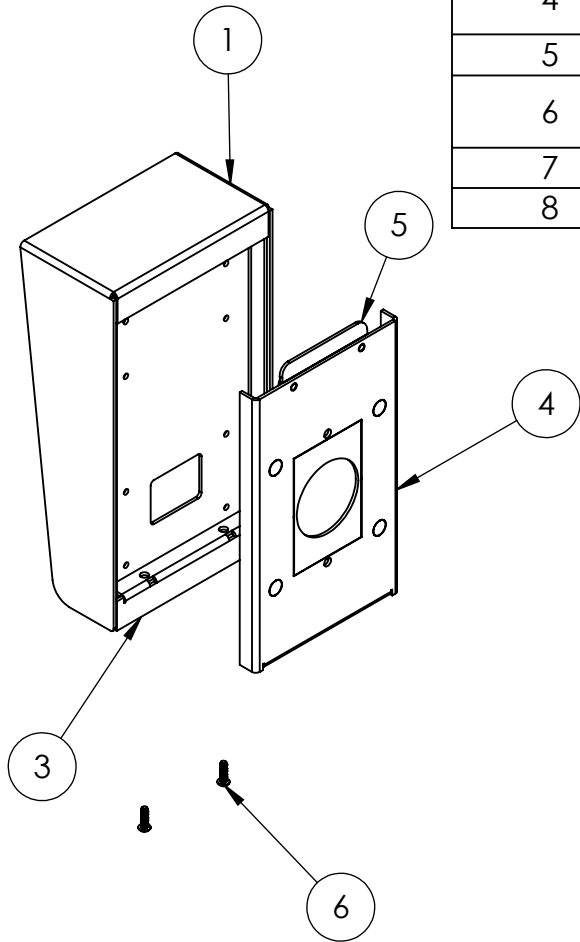

NOTES:

- SEE STANDARD PREPARATION AND COATING INSTRUCTIONS FOR COATING PROCEDURE AND COLOR.
- SEE STANDARD PACKAGING INSTRUCTIONS FOR PACKAGING PROCEDURE.



PEDESTALPRO.COM  
1-800-660-3072

UNLESS OTHERWISE SPECIFIED:

DIMENSIONS ARE IN INCHES  
TOLERANCES:  
FRACTIONAL  $\pm 1/32$   
ANGULAR:  $\pm 2^\circ$   
TWO PLACE DECIMAL  $\pm 0.010$   
THREE PLACE DECIMAL  $\pm 0.005$

INTERPRET GEOMETRIC  
TOLERANCING PER:  
ASME Y14.5 -2009

NAME	DATE
DRAWN	
CHECKED	

PROPRIETARY AND CONFIDENTIAL

THE INFORMATION CONTAINED IN THIS DRAWING IS THE SOLE PROPERTY OF PEDESTALPRO LLC. ANY REPRODUCTION IN PART OR AS A WHOLE WITHOUT THE WRITTEN PERMISSION OF PEDESTALPRO LLC IS PROHIBITED.

TITLE:

ASSEMBLY

Tuesday, November  
25, 2025 3:51:40 PM

WEIGHT: 2.958

SIZE  
**A**

PART NO.  
48HOO-CREW-01-CRS

REV  
**A**

NO SCALE

SHEET 2 OF 8