

(4X) DRILL #29  
TAP 8-32

DETAIL A

DETAIL B

- NOTES:
1. 1/2"  $\phi$  MOUNTING HARDWARE IS RECOMMENDED FOR 5X5 BASEPLATE MODELS. L-BOLT-500, STUD-ANCHOR-500.
  2. 5/8"  $\phi$  MOUNTING HARDWARE IS RECOMMENDED FOR 8X8 AND 12X12 BASEPLATE MODELS. L-BOLT-625, STUD-ANCHOR-625
  3. MATERIALS OF CONSTRUCTION IS MILD STEEL
  4. 2-4 MIL BLACK WRINKLE POWDER COAT. (8017-91612)



PEDESTALPRO.COM  
1-800-660-3072

UNLESS OTHERWISE SPECIFIED:	NAME	DATE
DIMENSIONS ARE IN INCHES	DRAWN	
TOLERANCES:	CHECKED	
FRACTIONAL: $\pm 1/32$	<b>PROPRIETARY AND CONFIDENTIAL</b>	
ANGULAR: $\pm 2^\circ$	THE INFORMATION CONTAINED IN THIS DRAWING IS THE SOLE PROPERTY OF PEDESTALPRO LLC. ANY REPRODUCTION IN PART OR AS A WHOLE WITHOUT THE WRITTEN PERMISSION OF PEDESTALPRO LLC IS PROHIBITED.	
TWO PLACE DECIMAL $\pm 0.010$		
THREE PLACE DECIMAL $\pm 0.005$		
INTERPRET GEOMETRIC TOLERANCING PER: ASME Y14.5 -2009		

TITLE:	INSTALLATION		
DATE:	Thursday, October 25, 2018 3:57:46 PM	SIZE	PART NO.
WEIGHT:		<b>A</b>	33PE1-AXIS-01-CRS (A4020-E)
			REV <b>B</b>
		NO SCALE	SHEET 1 OF 4

ITEM NO.	PART NUMBER	DESCRIPTION	QTY.
1	PLTBAS-8-3	8" STANDARD BASE PLATE	1
2	PLTCOV-8-3	8" STANDARD COVER PLATE	1
3	42-3-12	3X3 SQ STEEL TUBE	1
4	PLTFAC-3-4	MOUNTING PLATE	1
5	--	1/4-20 X .50 ZINC PL CARRIAGE BOLT	4
6	--	1/4-20 ZINC PL HEX NUT	4

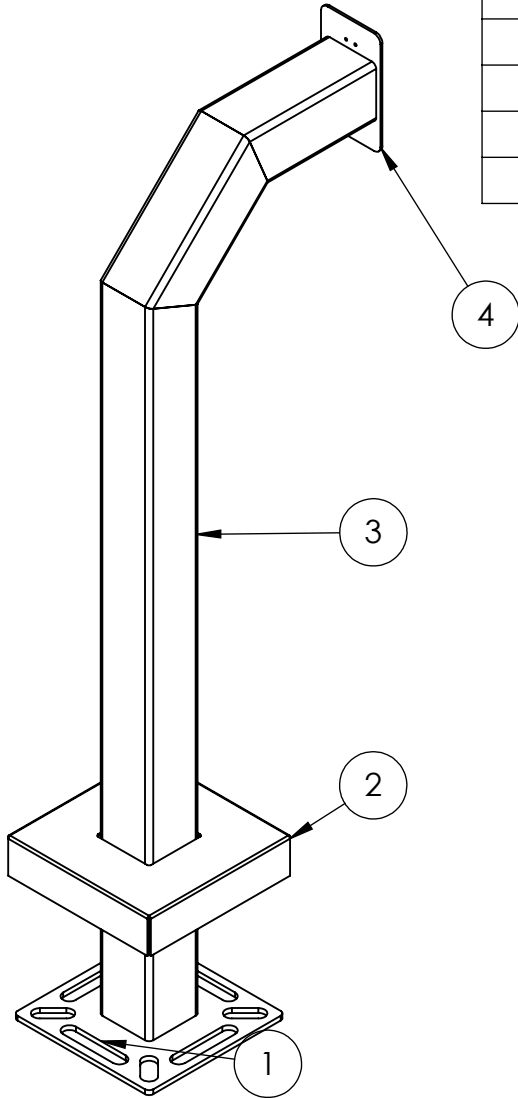

NOTES:

1. BUTT WELDED SECTIONS ARE NOT ALLOWED, EACH SECTION OF TUBE MUST BE FROM CONTINUOUS STOCK.
2. ALL WELDS ARE TO BE CONTINUOUS FILLET WELDS UNLESS NOTED OTHERWISE.
3. SEE STANDARD PREPARATION AND COATING INSTRUCTIONS FOR COATING PROCEDURE AND COLOR.
4. FASTENERS ARE TO BE BAGGED AND SHIPPED WITH PEDESTAL.
5. SEE STANDARD PACKAGING INSTUCTIONS FOR PACKAGING PROCEDURE.



PEDESTALPRO.COM  
1-800-660-3072

UNLESS OTHERWISE SPECIFIED:

DIMENSIONS ARE IN INCHES  
TOLERANCES:  
FRACTIONAL  $\pm 1/32$   
ANGULAR:  $\pm 2^\circ$   
TWO PLACE DECIMAL  $\pm 0.010$   
THREE PLACE DECIMAL  $\pm 0.005$

INTERPRET GEOMETRIC  
TOLERANCING PER:  
ASME Y14.5 -2009

NAME	DATE
DRAWN	
CHECKED	

**PROPRIETARY AND CONFIDENTIAL**

THE INFORMATION CONTAINED IN THIS DRAWING IS THE SOLE PROPERTY OF PEDESTALPRO LLC. ANY REPRODUCTION IN PART OR AS A WHOLE WITHOUT THE WRITTEN PERMISSION OF PEDESTALPRO LLC IS PROHIBITED.

TITLE:  
**ASSEMBLY**

Thursday, October 25,  
2018 3:57:46 PM

WEIGHT:

SIZE <b>A</b>	PART NO. 33PE1-AXIS-01-CRS (A4020-E)
------------------	---

REV <b>B</b>
-----------------

NO SCALE

SHEET 2 OF 4