

NOTES:  
 1. MATERIAL OF CONSTRUCTION IS 304 SS, BRUSHED #4.



PEDESTALPRO.COM  
 1-800-660-3072

UNLESS OTHERWISE SPECIFIED:

DIMENSIONS ARE IN INCHES  
 TOLERANCES:  
 FRACTIONAL: ± 1/32  
 ANGULAR: ± 2°  
 TWO PLACE DECIMAL ± 0.010  
 THREE PLACE DECIMAL ± 0.005

INTERPRET GEOMETRIC  
 TOLERANCING PER:  
 ASME Y14.5 -2009

NAME DATE

DRAWN

CHECKED

PROPRIETARY AND CONFIDENTIAL

THE INFORMATION CONTAINED IN THIS  
 DRAWING IS THE SOLE PROPERTY OF  
 PEDESTALPRO LLC. ANY REPRODUCTION  
 IN PART OR AS A WHOLE WITHOUT THE  
 WRITTEN PERMISSION OF PEDESTALPRO LLC  
 IS PROHIBITED.

TITLE:

INSTALLATION

Thursday, October 31,  
 2024 11:31:59 AM

WEIGHT: 18.103

SIZE  
**A**

PART NO.  
 22PE1-EBMU-02-304

REV  
**A**

NO SCALE

SHEET 1 OF 5

ITEM NO.	PART NUMBER	DESCRIPTION	QTY.
1	22PE1-EBMU-02-304	TOWER WELDMENT	1
2	PLTFAC-4-2	FACEPLATE	1
3	PLTCOV-5-2	COVER PLATE	1
4	PLTBAS-5-2	BASE PLATE	1
5	22PE1-EBMU-02-304 ACCESS PANEL	ACCESS PANEL	1
6	--	8-32 X 1/2" FLAT HEAD SECURITY SCREW	2
7	--	1/4-20 X .5 ZINC PL CARRIAGE BOLT	4
8	--	1/4-20 ZINC PL HEX NUT	4

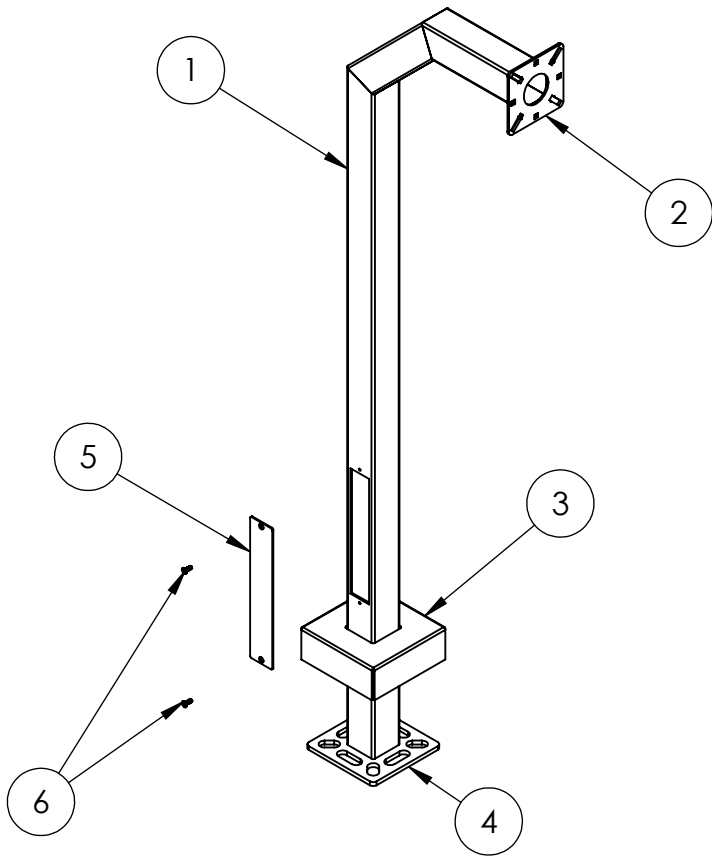

NOTES:

1. SEE STANDARD PREPARATION AND COATING INSTRUCTIONS FOR COATING PROCEDURE AND COLOR.
2. SEE STANDARD PACKAGING INSTRUCTIONS FOR PACKAGING PROCEDURE.



PEDESTALPRO.COM  
1-800-660-3072

UNLESS OTHERWISE SPECIFIED:

DIMENSIONS ARE IN INCHES  
TOLERANCES:  
FRACTIONAL  $\pm 1/32$   
ANGULAR:  $\pm 2^\circ$   
TWO PLACE DECIMAL  $\pm 0.010$   
THREE PLACE DECIMAL  $\pm 0.005$

INTERPRET GEOMETRIC  
TOLERANCING PER:  
ASME Y14.5 -2009

NAME DATE

DRAWN

CHECKED

**PROPRIETARY AND CONFIDENTIAL**

THE INFORMATION CONTAINED IN THIS  
DRAWING IS THE SOLE PROPERTY OF  
PEDESTALPRO LLC. ANY REPRODUCTION  
IN PART OR AS A WHOLE WITHOUT THE  
WRITTEN PERMISSION OF PEDESTALPRO LLC  
IS PROHIBITED.

TITLE:

ASSEMBLY

Thursday, October 31,  
2024 11:31:59 AM

WEIGHT: 18.103

SIZE  
**A**

PART NO.

22PE1-EBMU-02-304

NO SCALE

REV  
**A**

SHEET 2 OF 5