

NOTES:  
 1. MATERIAL OF CONSTRUCTION IS 304 SS, BRUSHED #4.



PEDESTALPRO.COM  
 1-800-660-3072

UNLESS OTHERWISE SPECIFIED:

DIMENSIONS ARE IN INCHES  
 TOLERANCES:  
 FRACTIONAL:  $\pm 1/32$   
 ANGULAR:  $\pm 2^\circ$   
 TWO PLACE DECIMAL:  $\pm 0.010$   
 THREE PLACE DECIMAL:  $\pm 0.005$

INTERPRET GEOMETRIC  
 TOLERANCING PER:  
 ASME Y14.5 -2009

NAME	DATE
PE	
CHECKED	

**PROPRIETARY AND CONFIDENTIAL**  
 THE INFORMATION CONTAINED IN THIS  
 DRAWING IS THE SOLE PROPERTY OF  
 PEDESTALPRO LLC. ANY REPRODUCTION  
 IN PART OR AS A WHOLE WITHOUT THE  
 WRITTEN PERMISSION OF PEDESTALPRO LLC  
 IS PROHIBITED.

TITLE:  
**INSTALLATION**

Thursday, June 12,  
 2025 2:15:02 PM

WEIGHT: 18.260

SIZE	PART NO.	REV
<b>A</b>	22PE1-CELL-01-304	<b>A</b>
NO SCALE		SHEET 1 OF 4

ITEM NO.	PART NUMBER	DESCRIPTION	QTY.
1	22PE1-CELL-01-304	TOWER WELDMENT	1
2	22PE1-CELL-01-304 FACE PLATE	FACEPLATE	1
3	PLTBAS-5-2	BASE PLATE	1
4	PLTCOV-5-2	COVER PLATE	1
5	--	1/4-20 X .5 ZINC PL CARRIAGE BOLT	4
6	--	1/4-20 ZINC PL HEX NUT	4

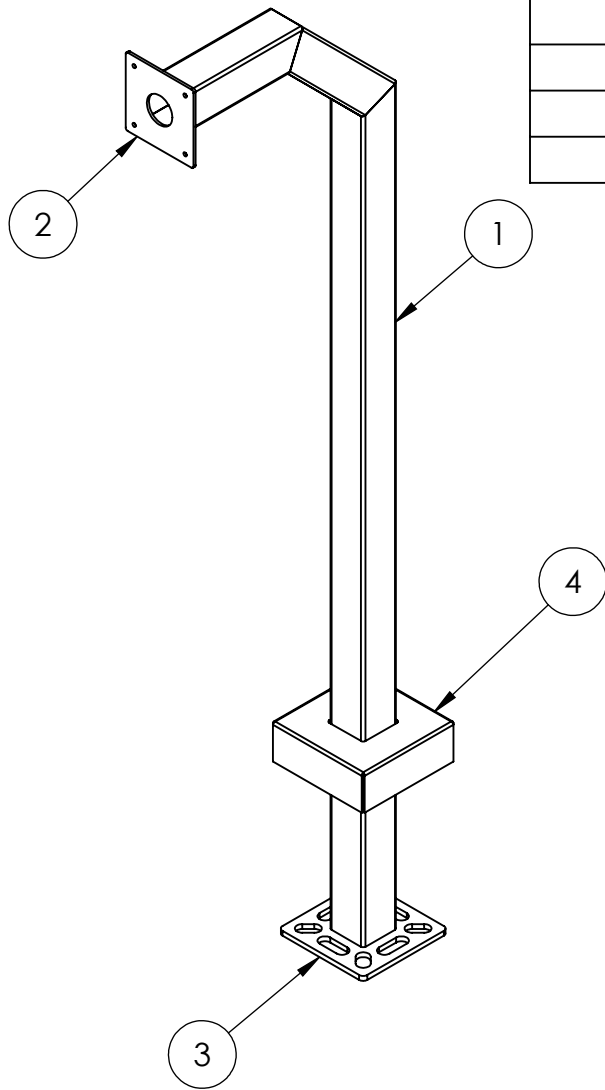

NOTES:

- SEE STANDARD PREPARATION AND COATING INSTRUCTIONS FOR COATING PROCEDURE AND COLOR.
- SEE STANDARD PACKAGING INSTRUCTIONS FOR PACKAGING PROCEDURE.



PEDESTALPRO.COM  
1-800-660-3072

UNLESS OTHERWISE SPECIFIED:

DIMENSIONS ARE IN INCHES  
TOLERANCES:  
FRACTIONAL  $\pm 1/32$   
ANGULAR:  $\pm 2^\circ$   
TWO PLACE DECIMAL  $\pm 0.010$   
THREE PLACE DECIMAL  $\pm 0.005$

INTERPRET GEOMETRIC  
TOLERANCING PER:  
ASME Y14.5 -2009

NAME	DATE
DRAWN	
CHECKED	

**PROPRIETARY AND CONFIDENTIAL**  
THE INFORMATION CONTAINED IN THIS  
DRAWING IS THE SOLE PROPERTY OF  
PEDESTALPRO LLC. ANY REPRODUCTION  
IN PART OR AS A WHOLE WITHOUT THE  
WRITTEN PERMISSION OF PEDESTALPRO LLC  
IS PROHIBITED.

TITLE:  
**ASSEMBLY**

Thursday, June 12, 2025 2:15:02 PM	SIZE <b>A</b>	PART NO. 22PE1-CELL-01-304	REV <b>A</b>
WEIGHT: 18.260	NO SCALE		SHEET 2 OF 4