

NOTES:

1. MATERIAL OF CONSTRUCTION IS MILD STEEL.
2. 2-4 MILS BLACK WRINKLE POWDER COAT.
1. PWDR-BLACK-WRINKLE



PEDESTALPRO.COM
1-800-660-3072

UNLESS OTHERWISE SPECIFIED:

DIMENSIONS ARE IN INCHES
TOLERANCES:
FRACTIONAL ± 1/32
ANGULAR: ± 2°
TWO PLACE DECIMAL ± 0.010
THREE PLACE DECIMAL ± 0.005

INTERPRET GEOMETRIC
TOLERANCING PER:
ASME Y14.5 -2009

NAME DATE

DRAWN

CHECKED

PROPRIETARY AND CONFIDENTIAL

THE INFORMATION CONTAINED IN THIS
DRAWING IS THE SOLE PROPERTY OF
PEDESTALPRO LLC. ANY REPRODUCTION
IN PART OR AS A WHOLE WITHOUT THE
WRITTEN PERMISSION OF PEDESTALPRO LLC
IS PROHIBITED.

TITLE:

INSTALLATION

Tuesday, August 27,
2024 11:42:48 AM

WEIGHT: 19.349

SIZE
A

PART NO.
22PE1-AIPH-10-CRS

REV
A

NO SCALE

SHEET 1 OF 6

ITEM NO.	PART NUMBER	DESCRIPTION	QTY.
1	22PE1-AIPH-10-CRS	TOWER WELDMENT	1
2	JO-1FD FACE PLATE	FACE PLATE	1
3	JO-1FD BACK PLATE	BACK PLATE	1
4	PLTCOV-5-2	COVER PLATE	1
5	PLTBAS-5-2	BASE PLATE	1

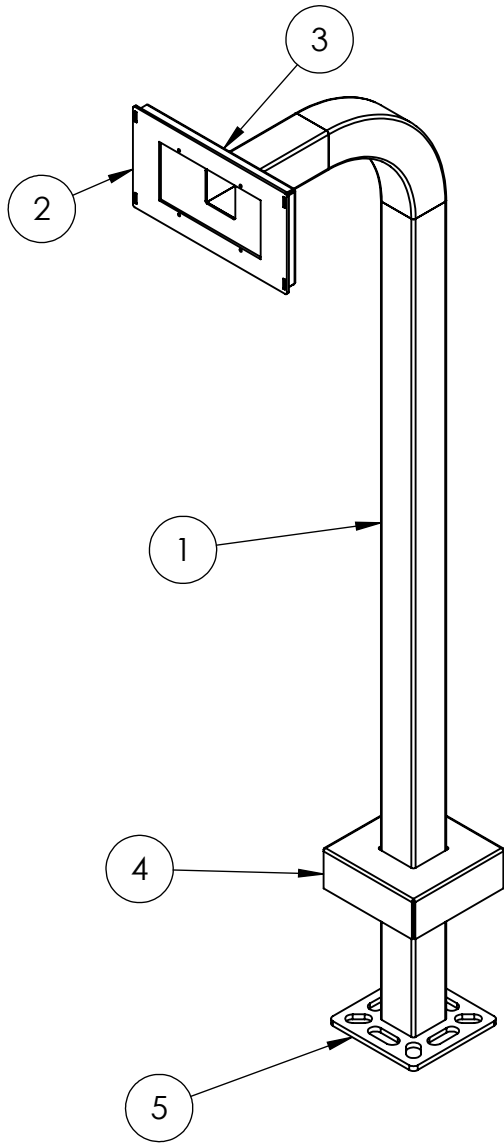

NOTES:

- SEE STANDARD PREPARATION AND COATING INSTRUCTIONS FOR COATING PROCEDURE AND COLOR.
- SEE STANDARD PACKAGING INSTRUCTIONS FOR PACKAGING PROCEDURE.



PEDESTALPRO.COM
1-800-660-3072

UNLESS OTHERWISE SPECIFIED:

DIMENSIONS ARE IN INCHES
TOLERANCES:
FRACTIONAL $\pm 1/32$
ANGULAR: $\pm 2^\circ$
TWO PLACE DECIMAL ± 0.010
THREE PLACE DECIMAL ± 0.005

INTERPRET GEOMETRIC
TOLERANCING PER:
ASME Y14.5 -2009

NAME	DATE
DRAWN	
CHECKED	

PROPRIETARY AND CONFIDENTIAL
THE INFORMATION CONTAINED IN THIS
DRAWING IS THE SOLE PROPERTY OF
PEDESTALPRO LLC. ANY REPRODUCTION
IN PART OR AS A WHOLE WITHOUT THE
WRITTEN PERMISSION OF PEDESTALPRO LLC
IS PROHIBITED.

TITLE:
ASSEMBLY

Tuesday, August 27,
2024 11:42:48 AM

WEIGHT: 19.349

SIZE	PART NO.	REV
A	22PE1-AIPH-10-CRS	A
NO SCALE		SHEET 2 OF 6