

NOTES:
 1. MATERIAL OF CONSTRUCTION IS #316 SS, BRUSHED #4 FINISH.



PEDESTALPRO.COM
 1-800-660-3072

UNLESS OTHERWISE SPECIFIED: ★
 DIMENSIONS ARE IN INCHES
 TOLERANCES:
 FRACTIONAL $\pm 1/32$
 ANGULAR: $\pm 2^\circ$
 TWO PLACE DECIMAL ± 0.010
 THREE PLACE DECIMAL ± 0.005
 INTERPRET GEOMETRIC
 TOLERANCING PER:
 ASME Y14.5 -2009

★	NAME	DATE
DRAWN		
CHECKED		
PROPRIETARY AND CONFIDENTIAL		
THE INFORMATION CONTAINED IN THIS DRAWING IS THE SOLE PROPERTY OF PEDESTALPRO LLC. ANY REPRODUCTION IN PART OR AS A WHOLE WITHOUT THE WRITTEN PERMISSION OF PEDESTALPRO LLC IS PROHIBITED.		

TITLE:
INSTALLATION

Monday, January 27, 2025
 12:15:46 PM

WEIGHT: 14.568

SIZE	PART NO.	REV
A	1410HOU-EBMU-02-316	A
NO SCALE		SHEET 1 OF 8

ITEM NO.	PART NUMBER	DESCRIPTION	QTY.
1	1410HOU-EBMU-02-316 ENCLOSURE	ENCLOSURE WELDMENT	1
2	1410HOU-EBMU-02-316 DOOR	DOOR WELDMENT	1
3	1410HOU-EBMU-02-316 HOOD	HOOD	1
4	HINGE	PIANO HINGE	1
5	GASKET SIDE	3/8" X .150 WEATHERSTRIPPING	2
6	GASKET TOP	3/8" X .150 WEATHERSTRIPPING	1
7	--	6-32 PAN HEAD SCREW	6
8	--	6-32 EXTERNAL TOOTH LOCK NUT	6
9	SFIC-LFIC LOCK BRACKET	LOCK BRACKET	1
10	TAMPER SWITCH BRACKET	SWITCH BRACKET	1
11	--	8-32 X .375" SS PEM STUD	4
12	--	8-32 KEPS NUT	4

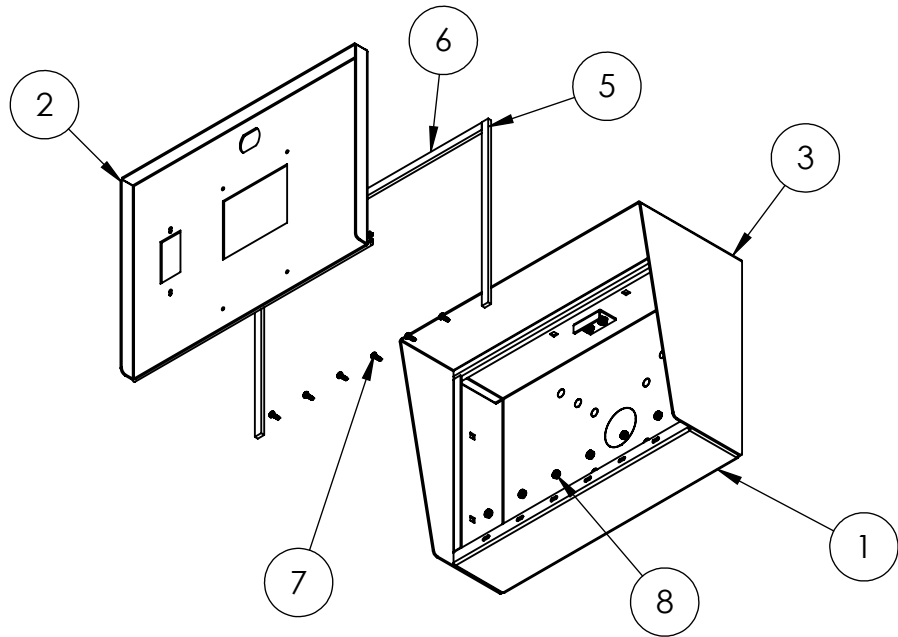

NOTES:

- SEE STANDARD PREPARATION AND COATING INSTRUCTIONS FOR COATING PROCEDURE AND COLOR.
- SEE STANDARD PACKAGING INSTRUCTIONS FOR PACKAGING PROCEDURE.



PEDESTALPRO.COM
1-800-660-3072

UNLESS OTHERWISE SPECIFIED:

DIMENSIONS ARE IN INCHES
TOLERANCES:
FRACTIONAL $\pm 1/32$
ANGULAR: $\pm 2^\circ$
TWO PLACE DECIMAL ± 0.010
THREE PLACE DECIMAL ± 0.005

INTERPRET GEOMETRIC
TOLERANCING PER:
ASME Y14.5 -2009

NAME	DATE
DRAWN	
CHECKED	

PROPRIETARY AND CONFIDENTIAL
THE INFORMATION CONTAINED IN THIS DRAWING IS THE SOLE PROPERTY OF PEDESTALPRO LLC. ANY REPRODUCTION IN PART OR AS A WHOLE WITHOUT THE WRITTEN PERMISSION OF PEDESTALPRO LLC IS PROHIBITED.

TITLE:
ASSEMBLY

Monday, January 27, 2025
12:15:46 PM

WEIGHT: 14.568

SIZE	PART NO.	REV
A	1410HOU-EBMU-02-316	A
NO SCALE		SHEET 2 OF 8